

STRAIGHT PLUG CRIMP TYPE

R114.082.400

CABLE 2.6/50+75 S

Series : SMB

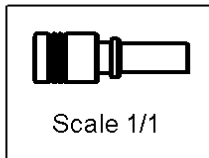
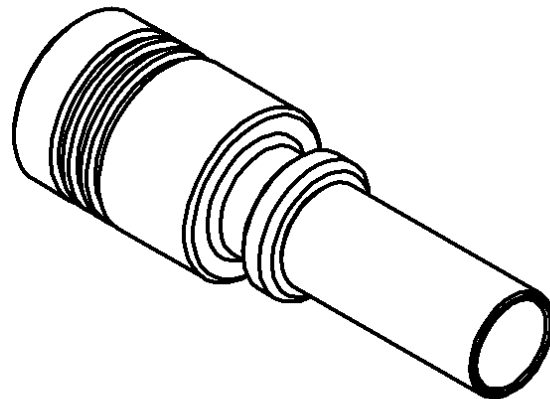
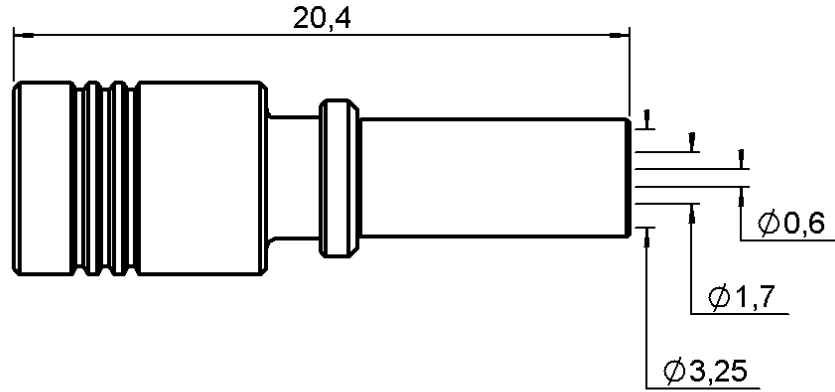

All dimensions are in mm.



COMPONENTS	MATERIALS	PLATINGS (µm)
BODY	BRASS	GOLD 0.2 OVER NICKEL 2
CENTER CONTACT	BERYLLIUM COPPER	GOLD 2.5 OVER COPPER 2.5
OUTER CONTACT	BERYLLIUM COPPER	GOLD 0.5 OVER NICKEL 2
INSULATOR	PTFE	
GASKET	-	
OTHERS PARTS	BRASS	NICKEL 2
-	-	-
-	-	-

Issue : 0215 A

In the effort to improve our products, we reserve the right to make changes judged to be necessary.



STRAIGHT PLUG CRIMP TYPE

R114.082.400

CABLE 2.6/50+75 S

Series : **SMB**

PACKAGING

Standard	Unit	Other
1	-	Contact us

SPECIFICATION

ELECTRICAL CHARACTERISTICS

Impedance		50 Ω
Frequency		0-4 GHz
VSWR	1.25 +	0.040 x F(GHz) Maxi
Insertion loss		0.25 √F(GHz) dB Maxi
RF leakage	- (57 - F(GHz)) dB Maxi
Voltage rating		335 Veff Maxi
Dielectric withstanding voltage		1000 Veff mini
Insulation resistance		1000 MΩ mini

CABLE ASSEMBLY

Stripping	a	b	c	d	e	f
mm	3.00	6.00	12.0	0.00	9.00	0.00

Assembly instruction : **Crimp 01**

Recommended cable(s)
 RG 316
 RG 179
 RG 187
 KX 22A
 RG 188

Cable retention
 - pull off **110** N mini
 - torque **NA** N.cm

MECHANICAL CHARACTERISTICS

Center contact retention		
Axial force – Mating end	10	N mini
Axial force – Opposite end	10	N mini
Torque	NA	N.cm mini

TOOLING

Part Number	Description	Hexagon
.	.	.
R282.211.000	CRIMPING TOOL	3.25
R282.235.003	CRIMPING DIES	3.25
R282.281.000	CRIMPING TOOL	2x4(pos.3- >50 pos.1- >75)
R282.293.000	CRIMPING TOOL	-

Recommended torque		
Mating	NA	N.cm
Panel nut	NA	N.cm
Clamp nut	NA	N.cm
A/F clamp nut	0.000	mm

Mating life	500	Cycles mini
Weight	2.100	g

OTHERS CHARACTERISTICS

-

ENVIRONMENTAL

Operating temperature	-65/+165	° C
Hermetic seal	NA	Atm.cm3/s
Panel leakage	NA	

Issue : **0215 A**

In the effort to improve our products, we reserve the right to make changes judged to be necessary.

